



Sanitary Pressure Gauges



3S-EB-2U-GFBTSS

Sizes

- Dial size: 3-1/2" or 5" diameter

Materials

- Case: 304 stainless steel
- Lens: polycarbonate

Features

- Accuracy: $\pm 1.5\%$ of full scale
- Over range capacity: 30%
- Product contact: 316L stainless steel
- Surface finishes (product contact):
Ra max = 25 microinches
- Standard fill: food grade glycerin
- Rezero feature: standard on pointer
- Shipping weight: approximately 3 lbs. (1.3 kg)

Specification

- Temperature limits: 0°F to 250°F (-18°C to 121°C)

3-1/2" Gauge - (90 mm)

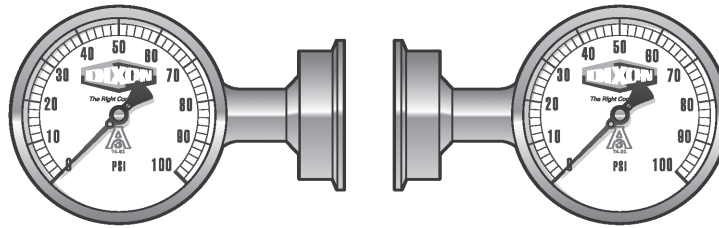
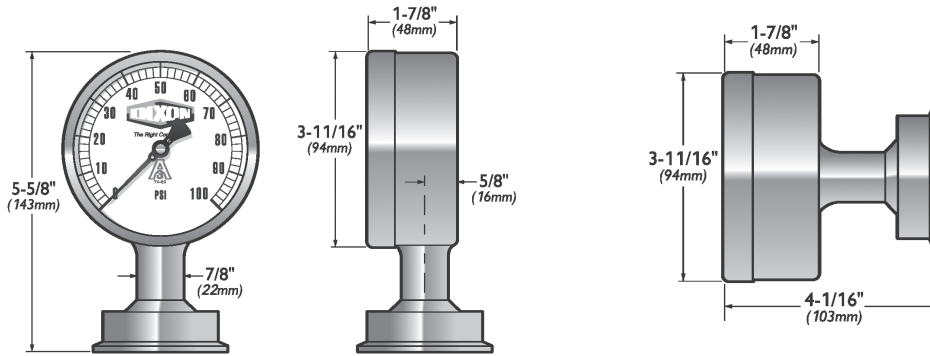

5" Gauge - (120 mm)

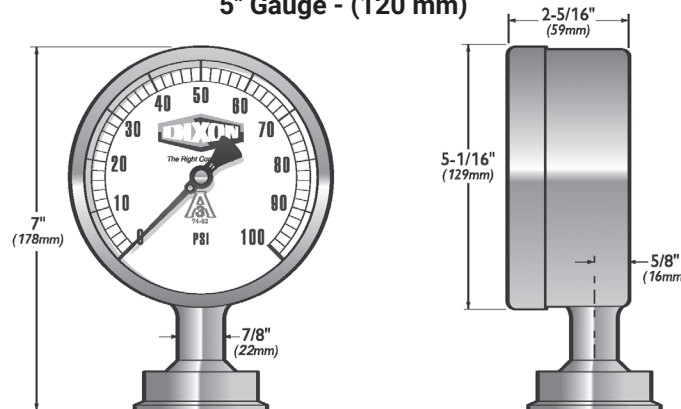

shown with 2" clamp

Product not returnable and no cancellations.

M