

### 150 Lb. Weld Neck ASA Forged Flanges

**Feature**

- Raised face

Size	Number of Bolts	Carbon Steel Part #
1"	4	WN100
1-1/4"		WN125
1-1/2"		WN150
2"		WN200
3"		WN300
4"	8	WN400
5"		WN500
6"		WN600
8"		WN800
10"		WN1000

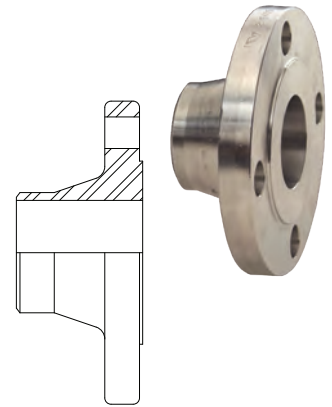

**Flange Gaskets**

**Features**

- Standard drop-ring type all 1/16" thick
- Reference page 1053 for joint sealant gasket material
- For flange dimensional information and diagrams please reference [canada.dixonvalve.com](http://canada.dixonvalve.com)

Size	Neoprene Part #	Klingersil® C-4401 Part #
1"	NG10	AG10
1-1/4"	NG15	AG15
1-1/2"	NG20	AG20
2"	NG25	AG25
2-1/2"	NG30	AG30
3"	NG35	AG35
4"	NG40	AG40
5"	NG50	---
6"	NG60	AG60
8"	NG80	AG80



carbon steel



Klingersil® C-4401

### ANSI Flat Face Flange x Male NST (NH)

**Materials**

- Flange - black powder coated carbon steel
- Male adapter - black anodized aluminum

Size	PSI	Carbon Steel / Aluminum Part #
6" NST (NH)	175	T600-60F



### King Turned Back Weld-To-Metal Hose Nipples

**Application**

- For use with slip-on and lap joint flanges shown on previous page

**Features**

- MSS Length
- Phono-finish face (type CS), except 10" and 12" have smooth face (type C)

Size	Length	Schedule 40 Plated Carbon Steel Part #	Schedule 40 316 Stainless Steel Part #
1"	2"	NW10	RNW10-40
1-1/4"	2"	NW15	RNW15-40
1-1/2"	2"	NW20	RNW20-40
2"	2-1/2"	NW25	RNW25-40
2-1/2"	2-1/2"	NW30	RNW30-40
3"	2-1/2"	NW35	RNW35-40
4"	3"	NW40	RNW40-40
6"	3-1/2"	NW60	RNW60-40
8"	4"	NW80	RNW80-40
10"	5"	NW100	RNW100-40
12"	6"	NW120	RNW120-40

