

Notice: This drawing contains proprietary information and shall not be used or reproduced or its contents disclosed in whole or in part, without the prior written consent of the Mann Teknik AB

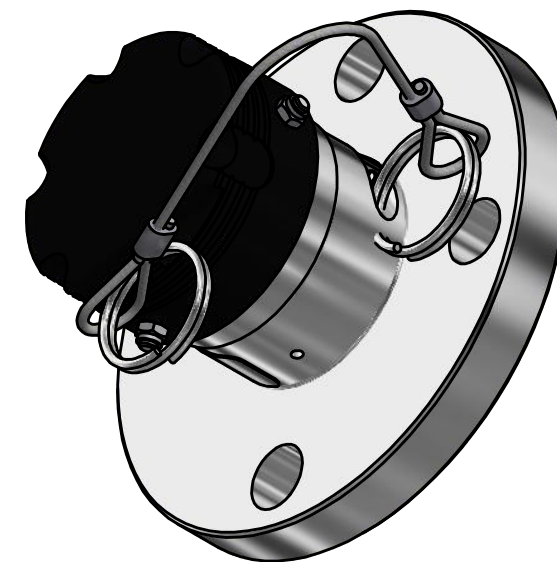
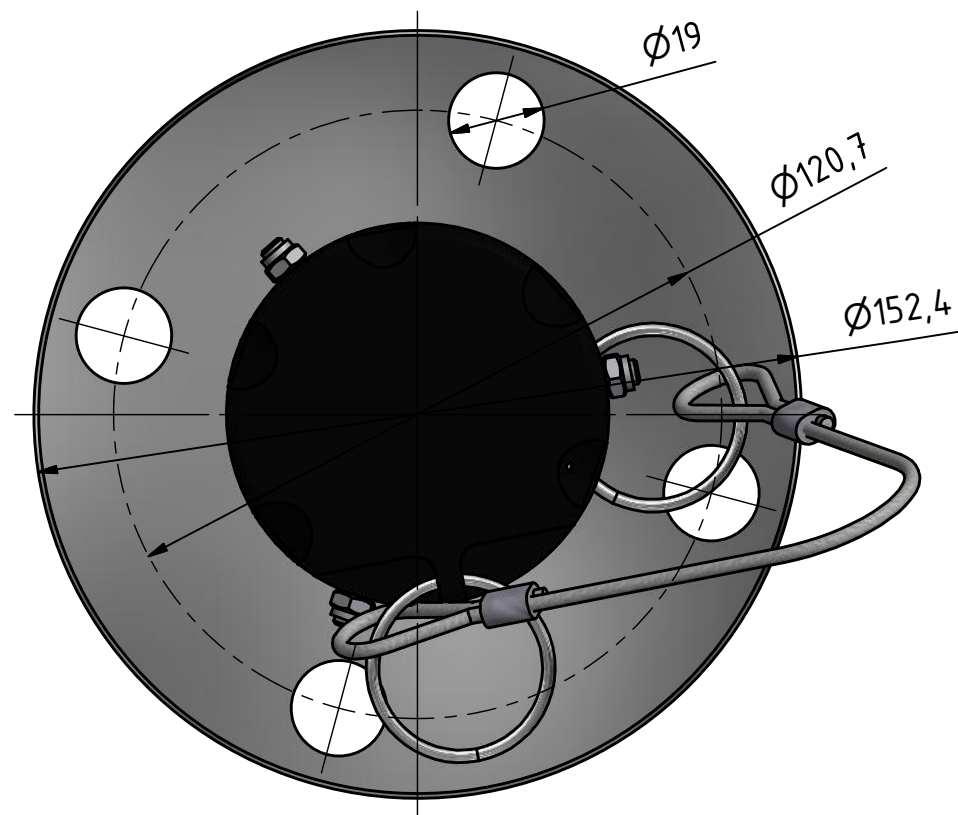
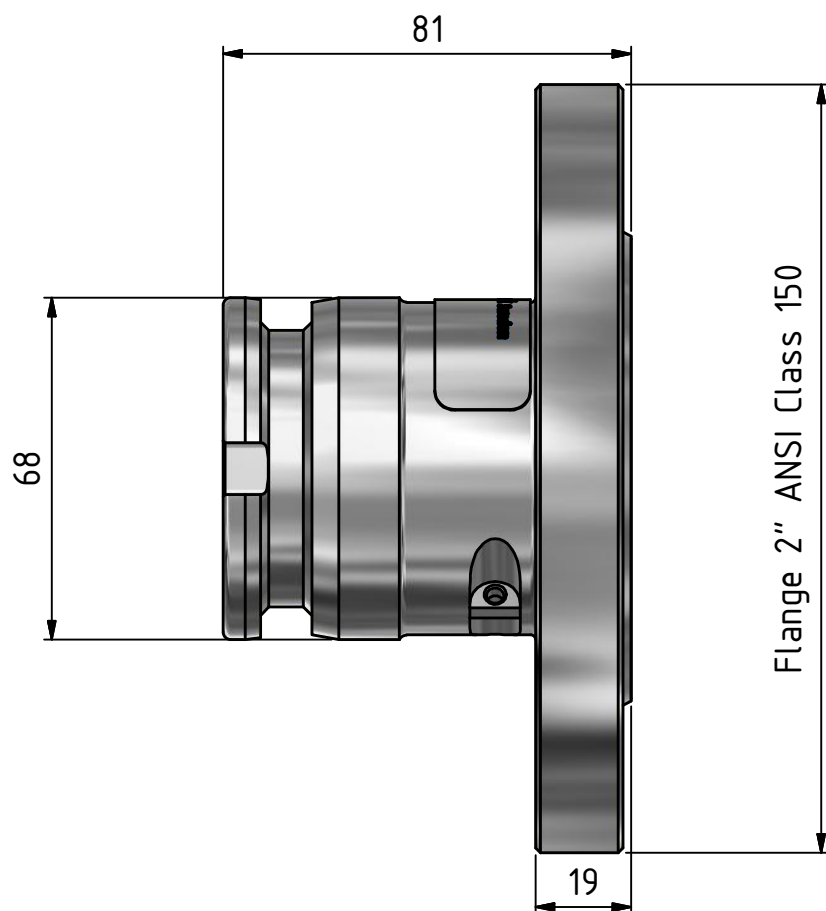
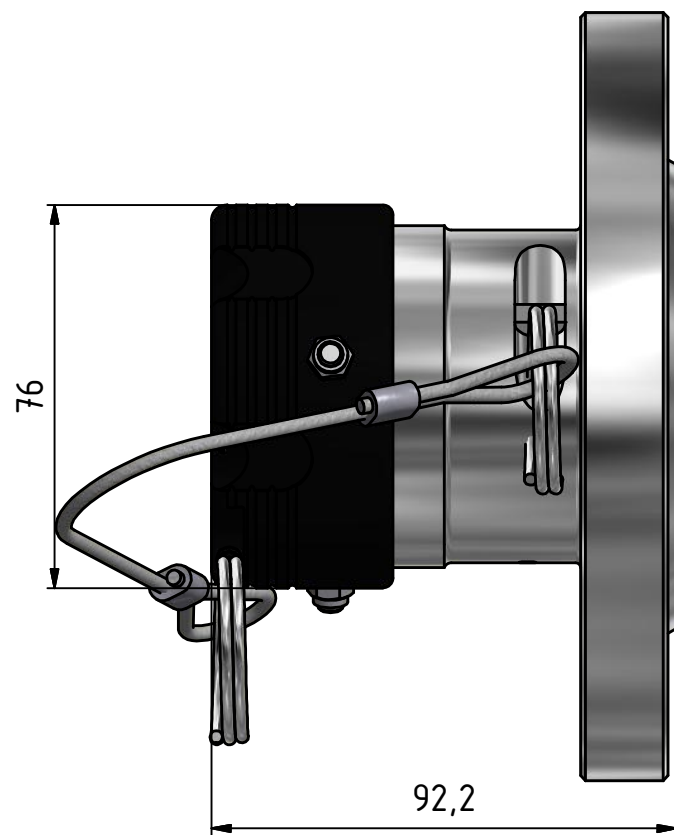

Dimensions are in metric.

3,2 kg

Detail No:	Material	Ämne/Blank	Ytbeh./Treatment	Vikt/Weight
Mann Tek	Designed/drawn by G. Li	Scale: 1:2	Dimension with no tolerances acc to Machined SS-ISO 2768-1 medium Weld Forge SS-ISO 2768-1 coarse Surface roughness SS-ISO 1302 Form & position tol SS-ISO 2768-2-K	
	Checked G. Kopplin			
	Approved T. Mann	Date 2013-05-15		
Tank unit 2" DCC with cap Flange 2" ANSI Class 150			Data nr./Comp No. LC2A_smst	Blad/Sheet 1 / 1
			Drawing No. LC257A44-1	Rev.

NO.	Revision comprises	Date	Sign.	Appr by