



DX60-Series Hygienic Tanker Valve

Application

- Used on 3A food-grade stainless steel bulk transport trailers to safely and hygienically load and unload various products including milk, juices, chocolate, glycerin, and many types of food-grade oils

Sizes

- 3", 6" x 3", and 6"

Materials

- All product contact metal components: 304 stainless steel
- All non-product contact steel components: 304 stainless steel
- Product contact seals: FKM or nitrile rubber (FDA 21CFR177.2600 & 3A 18-03 Class I)
- Stem bushings: PTFE

Specifications

- Holding pressure: 75 PSI
- Temperature range: -20°F to 212°F (-28.9°C to 100°C), for other ranges contact Dixon Sanitary
- Surface I.D. finish: ≤ 32Ra
- Connections
 - 3" flange with ANSI B16.5 class 150# flange bolt circle x 3" sanitary male threaded bevel seat
 - 6" sanitary triclamp flange x 3" sanitary male threaded bevel seat
 - 6" triclamp ferrule x 6" 90° outlet triclamp ferrule
 - Other connection types available upon request

Options

- 316L product contact components
- 15Ra, 20Ra, or 25Ra finishes available
- Valve plunger with conical freeze rod
- Aluminum cover

Approval

- 3A – authorization number 1655, 53-07 (compression-type valves) for CIP and COP

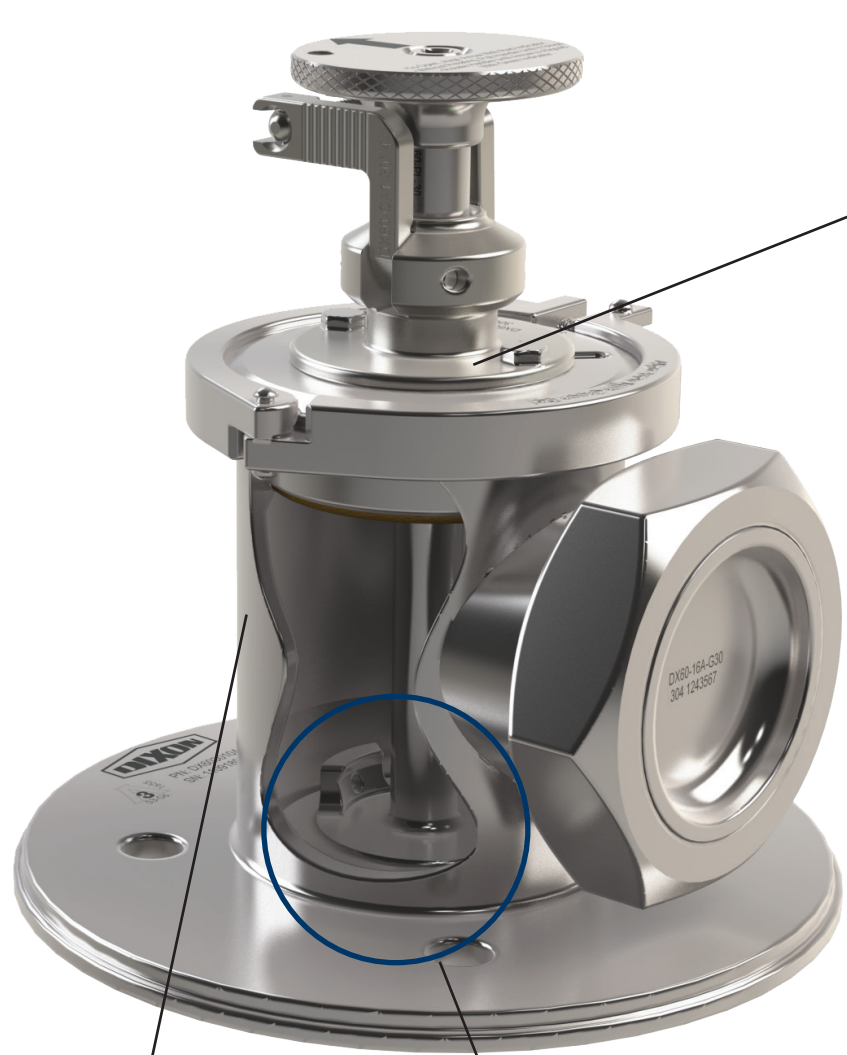

Hygienic Single Acting

Wiper lip seal provides improved cleanability, durability, and performance over standard O-ring seals in dynamic applications.

Bonnet Design

Uses standard sanitary clamp that allows the entire plunger and bonnet assembly to be removed quickly and easily with no tools required.

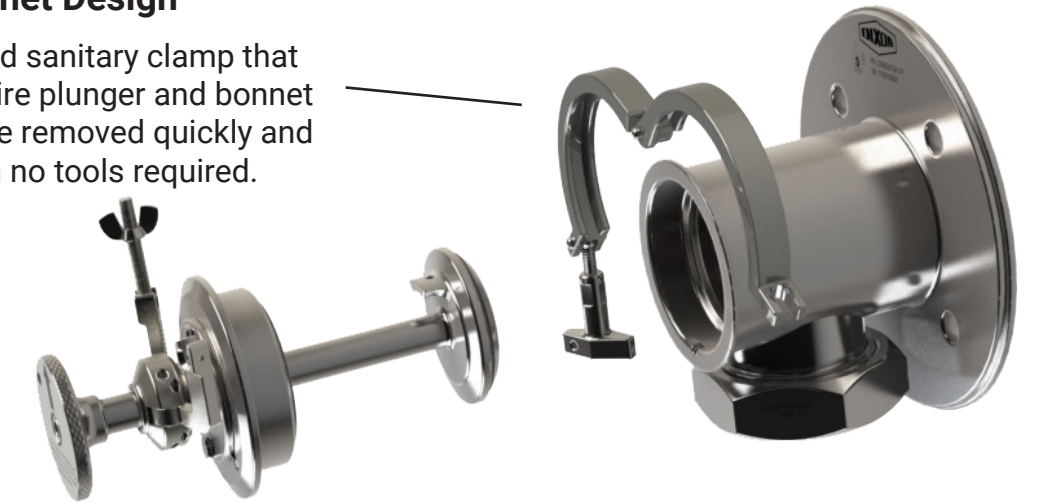

Conical Freeze Rod

Conical shaped rod allows flow around the rod as soon as the valve is slightly opened. Can be used for any product that does not flow easily.



Easy-Lock Plunger

Our unique lock-arm design allows the plunger to be locked in the open position by pulling the plunger to the open position and rotating the handle. No need for any external locking devices.

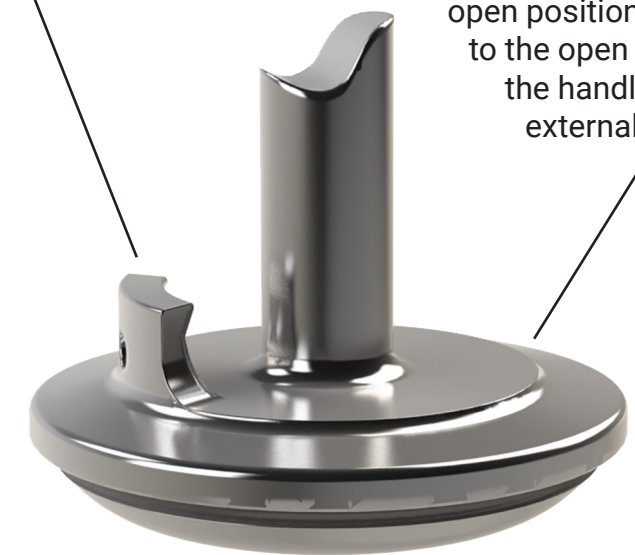

Valve Housing

Machined from solid bar with 5mm thick wall to provide reliable performance even in the most demanding applications. Internal geometry designed for optimal cleanability and drainability.

Patented Closure System

Only valve on the market that has eliminated the pinch point between the handle and bonnet. Includes cam arms with hinged locking eye bolt to prevent accidental opening.

