

Below are a few of the many configurations available. If you don't see one that meets your requirements then "Build It Your Way". On pages 4-6 we show some of the assembly components. Pick the parts for your specific application and you can either assemble it, or we can put it together for you. Call Dixon for help in the design of an assembly that will meet your needs.

Railcar Unloading Assemblies - Build It Your Way

Application:

- Easy connect / disconnect solutions for loading and unloading crude oil from rail cars.

Features:

- Productivity - multiple designs available to achieve efficient and safe unloading
- Flexibility - various product options meet challenges requiring customized assemblies
- Reliability - dry disconnect valves that will not open unless connections are properly mated

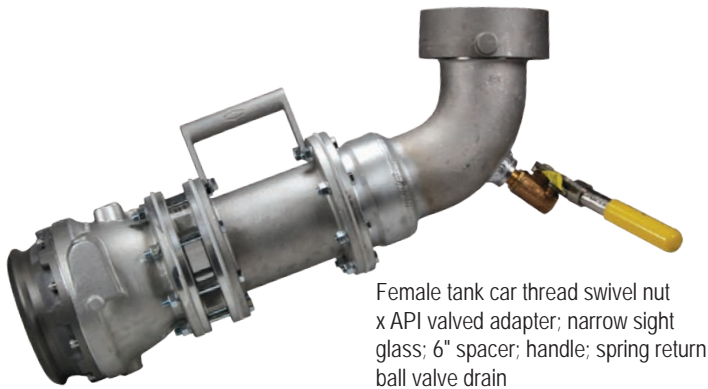

Female tank car thread swivel nut x API valved adapter; narrow sight glass; 6" spacer; handle; spring return ball valve drain

TF020001H20API

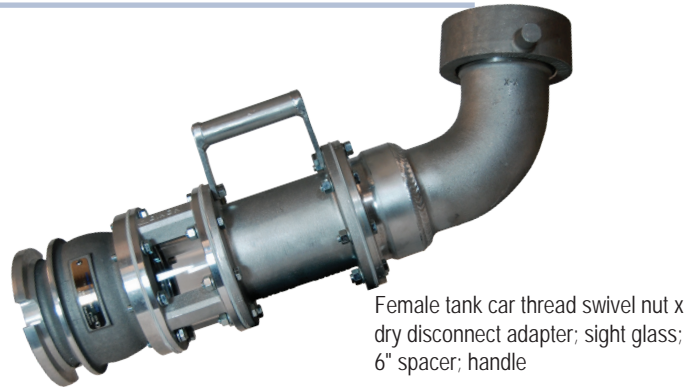

Female tank car thread swivel nut x dry disconnect adapter; sight glass; 6" spacer; handle

TF010001H10DDA

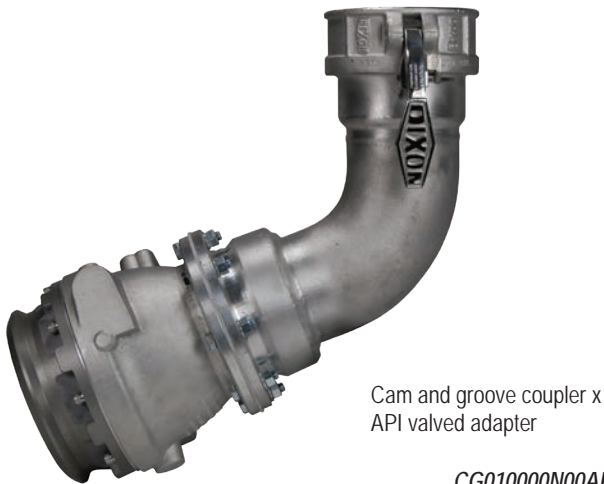

Cam and groove coupler x API valved adapter

CG010000N00API

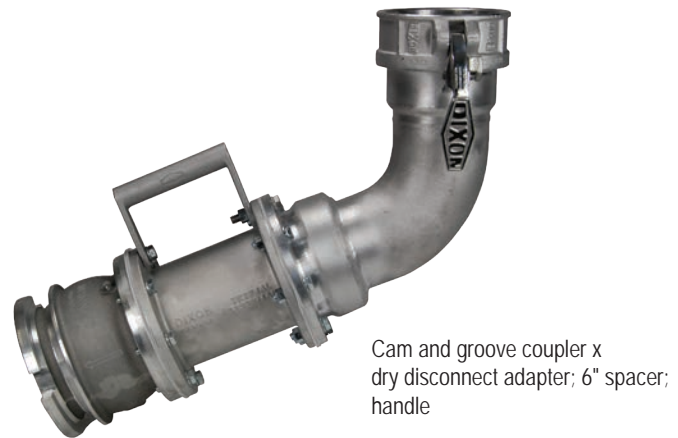

Cam and groove coupler x dry disconnect adapter; 6" spacer; handle

CG01001H00DDA

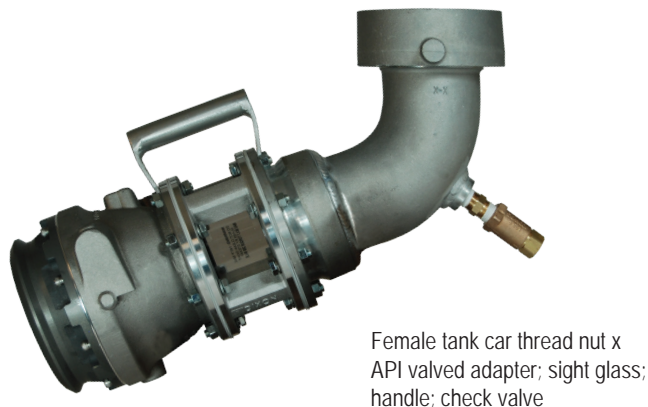

Female tank car thread nut x API valved adapter; sight glass; handle; check valve

ATC40FPSGHAPICV

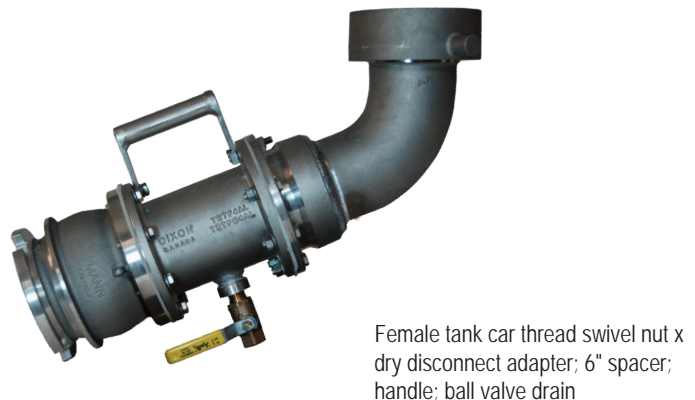

Female tank car thread swivel nut x dry disconnect adapter; 6" spacer; handle; ball valve drain

TF010003H00DDA

Transfer Hose Connection Examples

Transfer Hose with API Coupler

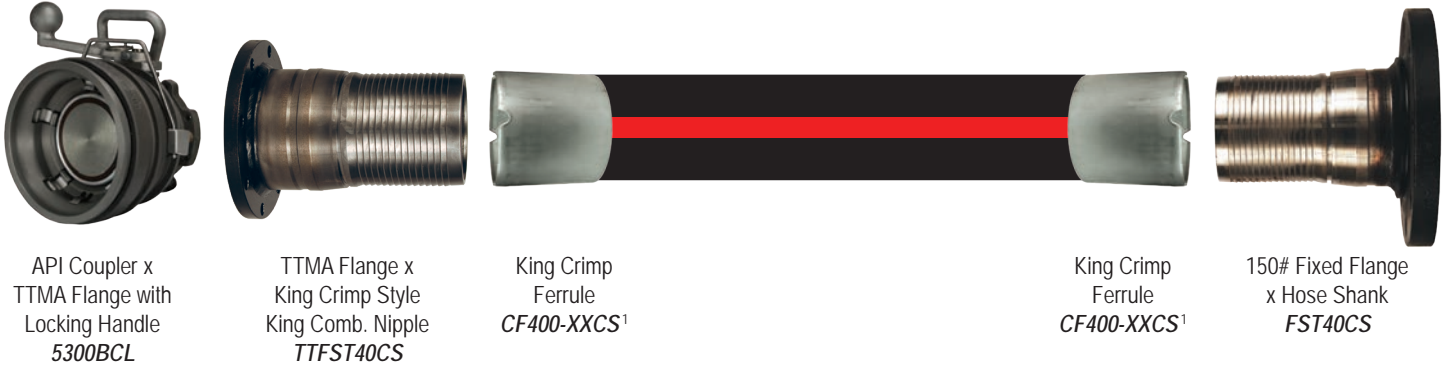

Transfer Hoses with Dry Disconnect Couplers

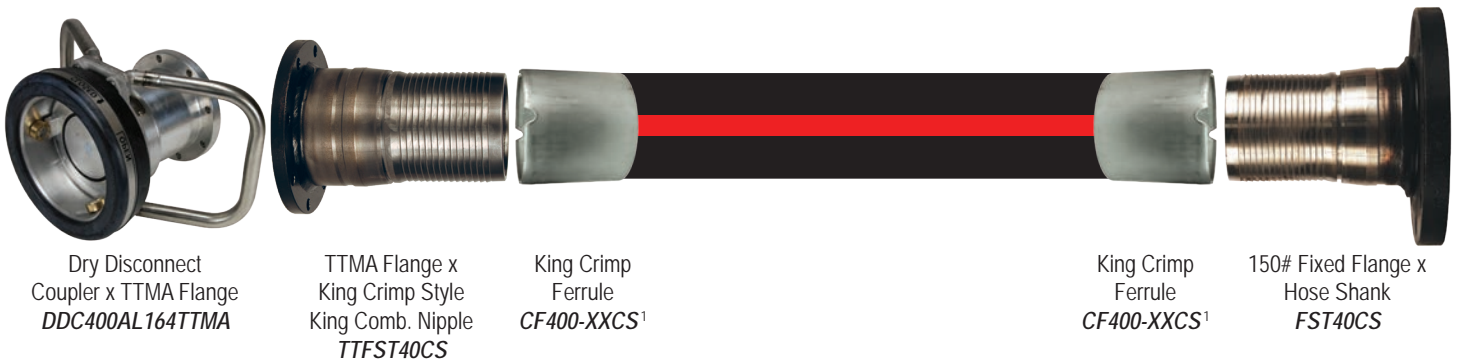

• Other TTMA Flange Adapter configurations are available, contact Dixon for additional information.

¹ Ferrule part numbers shown are for placement purposes only, the actual part number depends on the hose OD.

Railcar Unloading Components

Mates to a Tank Car



110° elbow with tank car threaded swivel nut x TTMA flange
ATCF40



90° elbow with cam and groove x TTMA flange
ATCGF40-90



110° elbow with tank car threaded swivel nut x TTMA flange with 1/2" FNPT port
ATCF40FP50



110° elbow with cam and groove x TTMA flange
ATCGF40



Female tank car thread x cam and groove adapter
400-TCA-AL



Dixon cam & groove coupler x male tank car thread
400DWX5TC



EZ Boss-Lock cam & groove coupler x male tank car thread
AD400ALEZMTC

Spacer with Port



TTMA Spacer with 1/2" FNPT port
TTFS4AL-FP50

1/2 Female NPT Port Options



Ball Valve
BMV50



Spring Return Ball Valve
BBV50SR¹



Check Valve
61-103¹

Flange Extension



TTMA Flange, 6" extension
TETF4AL



TTMA Flange, 6" Extension with 1/2" FNPT Port
TETF4ALFP50

Handle Option



HANDLE

¹ Ball and check valves are also available in stainless steel

Railcar Unloading Components

TTMA Flanged Sight Glasses



Sight glass (3/4" wide)
5201-SFI



Narrow sight glass (1 3/4" wide)
5200-SFI



Acrylic sight glass (1 3/4" wide)
TT4ASG



Acrylic ethanol sight glass (1 3/4" wide)
TT4ASG-ETH

TTMA Flange Screen / Gasket

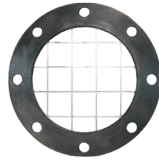

Screen with 1" square holes
TTFS4SS



PTFE envelope gasket with Baylast™ core
40322TF

Dry Disconnect Adapter



Dry disconnect adapter x TTMA flange
DDA400AL164TTMA

API Adapters



API adapter
(poppet opens with API coupler engagement only)
5204LSNG



API adapter with fixed handle
(poppet can open with API coupler engagement
or by using the handle)
5204NG

Cam and Groove Adapter



Cam & groove adapter x TTMA flange
400-ALT-AL

Accessories Plugs



5MTCP

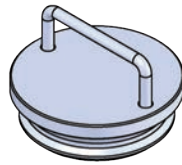

5354P1



DDDP400

Part #	Description
5MTCP	Threaded plug for tank car nut
5354P1	API coupler plug
DDDP400	Dry disconnect dust plug

Caps



DDDC400



5000-25

Part #	Description
DDDC400	Dry disconnect dust cap
5000-25	Nylon API dust cap / chain

Parking Adapters



TOOL504-1



5204H



5204H-SPEC

Part #	Description
TOOL504-1	Dry disconnect parking adapter
5204H	API parking adapter
5204H-SPEC	Low profile hanger for rack coupler, unassembled

Hardware Kits

Features:

- For use on one assembly end only
- Kits include: 8 each nuts, lock washers and bolts



TCABK-1.5

Part #	Description
TCABK-1.5	Replacement bolt kit, 1½" bolt length
TCABK-3	Replacement bolt kit, 3" bolt length
TCABK-3.5	Replacement bolt kit, 3½" bolt length

Spanner Wrench



Part #	Description
G10	Iron, used on aluminum and iron railcar nuts

Steam Hose Connections

GJ Boss™ Ground Joint Seal

Features:

- Easy, positive metal-to-polymer seal
- Leakproof seal forms when the metal head of the stem makes contact with the patented polymer seat in the spud
- Non-metallic polymer seat resists most chemicals found in manufacturing facilities; visit dixonvalve.com for corrosion resistance information
- Recommended for steam service up to **450°F (232°C)**
- Works with existing fittings
- Configurations: stem, nuts, spuds

Materials:

- Plated steel and / or iron

Sizes:

- ¾", 1", 1½", 2"



Warning: Do Not Disconnect Under Pressure!



Steam Quick Disconnect Couplings

Application:

- Designed exclusively for steam applications

Features:

- Coupler sleeve designed for easier gripping with gloves
- Two ethylene propylene O-rings in the coupler and one ethylene propylene O-ring in the plug provide double protection against leaks
- Rated to **200 PSI** gauge saturated steam **388°F (198°C)**
- Configurations: poppet valve couplers and plugs

Materials:

- Coupler and plug are solid brass with stainless steel springs and locking balls
- Coupler has a plated steel sleeve

Sizes:

- ¾", 1", 1½"



Warning: Do Not Disconnect Under Pressure!



Dry Disconnect Fittings for Steam Service

Application:

- Designed for steam hoses used for heating viscous products in tank car applications.

Features:

- Eliminates unintentional separation preventing accidents and avoiding unintended down time
- Performance unaffected by surface rust
- Maximum operating: **150 PSI**
- Maximum temperature rating: **350°F (177°C)**
- Lockable versions are available, contact Dixon for information
- Configurations: coupler x female NPT, adapter x female NPT

Materials:

- Coupling house and all inner parts: stainless steel
- EPDM seals standard, other materials available contact Dixon for information

Sizes:

- 1½", 2"



Note: Can be safely disconnected while in service.

Dixon, founded in 1916, is a premier manufacturer and supplier of hose couplings, valves, dry-disconnects, swivels, and other fluid transfer and control products. The company's global reach includes a wide range of products for numerous industries including petroleum exploration, refining, transportation, chemical processing, food & beverage, steel, fire protection, construction, mining and manufacturing. Dixon's strategic objective is to create solutions that make products safer, leak-free, longer lasting, and always available.

canada.dixonvalve.com • *Customer Service: 877.963.4966*



The Right Connection®

Dixon Group Canada Limited

2200 Logan Avenue, Winnipeg, MB R2R 0J2
isales@dixongroupcanada.com



YouTube™



Follow us
on Social Media



DGCL Customer Service

